

8 7 6 5 4 3 2 1

EXTERIOR COLOR:	ARCTIC WHITE
INTERIOR COLOR:	ARCTIC WHITE

H G F E D C B A

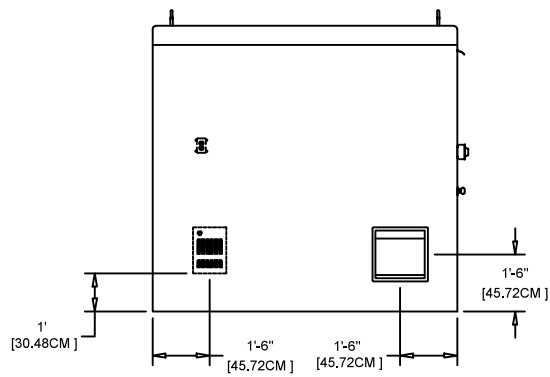

LEFT ELEVATION VIEW

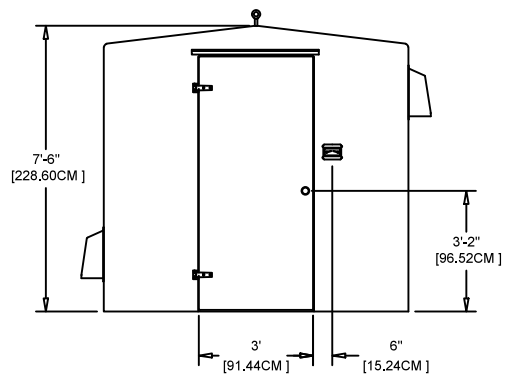

FRONT ELEVATION VIEW

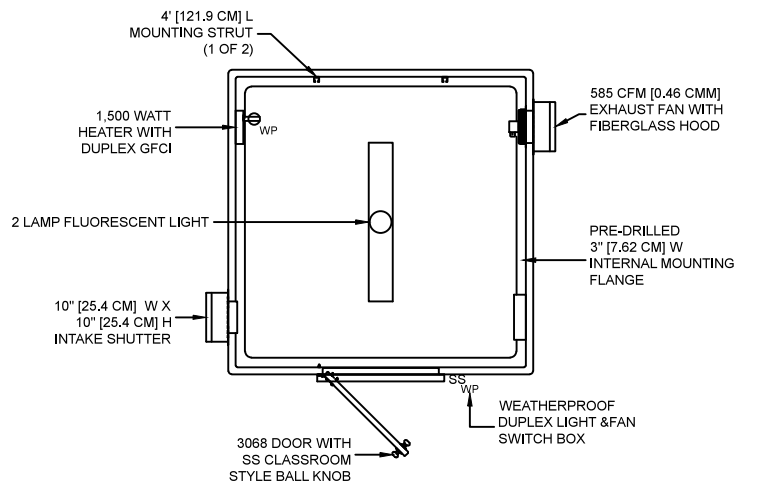

PLAN VIEW

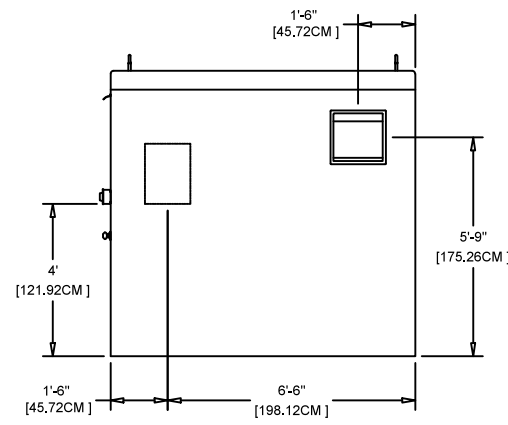

RIGHT ELEVATION VIEW

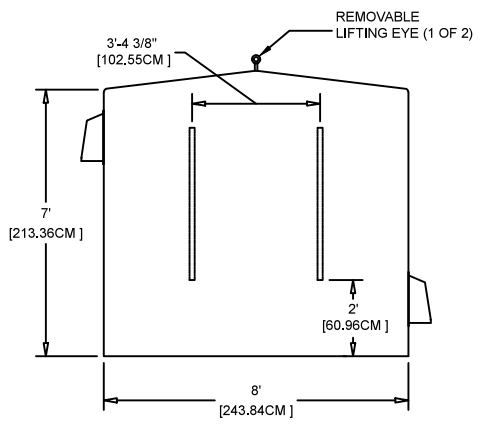

REAR ELEVATION VIEW

REV	REVISION DESCRIPTION	BY	DATE

NOTES:
 1) ANCHOR BOLTS AND CONCRETE PAD SIZING / SPACING BY OTHERS
 2) ENCAPSULATED 2" [5.08 CM] INSULATING FOAM CORE
 3) 15 MIL (MIN.) GEL COAT WITH U.V. INHIBITORS
 4) EQUIPMENT LOCATIONS ARE APPROXIMATE AND MAY BE CHANGED TO ACCOMMODATE CODE, SPACING CONFLICTS, OR OTHER TECHNICAL ISSUES AT WILL AND WITHOUT NOTICE

This drawing and the data contained within is the sole, confidential property of OPENCHANNELFLOW.COM (OCF) and may not be copied, reproduced, disclosed to others, in whole or in part, without the prior written consent of OCF. OCF reserves the right to change any dimension, finish, material, or method of construction indicated on this drawing at will and without notice. This drawing is provided in confidence with the understanding it shall be returned to OCF upon demand.

OPENCHANNELFLOW BOISE ATLANTA	
DWG NO. S-8-8 (1)	DATE 8.7.14
FIBERGLASS 8' W X 8' D SHELTER	
Unless otherwise indicated, dimensions are in feet and inches, with centimeters indicated in []. Angles are in degrees.	

8 7 6 5 4 3 2 1